

BossDim Wall Euro has a built-in sleep function that makes the light dim, from one light-level to another, in 30 minutes. The original settings are from 100% light to being switched off.

Activate sleep mode:

Press the left side of the bar and hold it in for four seconds after the maximum level is reached. A red light diode under the bar will slowly flash and the sleep-mode is activated.

Cancel sleep mode:

Press either the left or right side of the bar to cancel the sleep-mode.

Changing the start level:

Press both the left and right side of the bar at the same time and hold them in for four seconds. When the four seconds are up, a red light diode under the bar will begin flashing. Adapt the starting level of light after your wish and press the left side of the bar. The new starting level is now programmed.

Changing the stop level:

Repeat above, but finish by pressing the right side of the bar instead of the left.

BossDim Wall Euro lets you control your light. Either by using the black bar at the front of the dimmer or by using a remotecontrol.

Note: This manual is based on Beo4 from Bang & Olufsen.



Close-up Control:

Turning on and shutting off the light:

One short press of the left side of the bar will turn on the light. One short press on the right side of the bar will turn the lights off.

Adjusting the light:

One longer press on the left side of the bar will adjust the light towards maximum.

One longer press on the right side of the bar will adjust the light towards minimum.

Mounting diagram

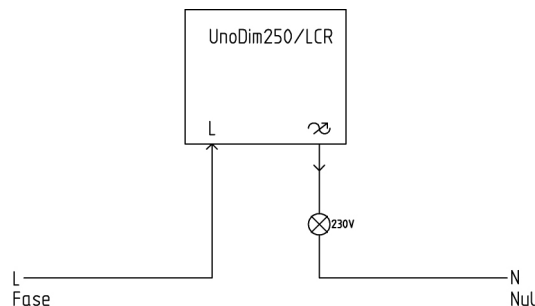

Specifications

Rated voltage	230VAC, 50 Hz
Rated power	20-250W incandescent lamps
	20-250VA low voltage halogen via iron core transformer
	20-250VA low voltage halogen via electronic transformer
Own consumption	<1 W
Fuse	Automatic
Front fuse	13A
Clips	1x1.5 mm ²
Ambient temperature	+5 C° til +35 C°
Humidity	5-95% RH, noncondensating

Remote Control:

Turning on and shutting off the lights:

Press [LIGHT] or alternatively [LIGHT] [GO] twice to turn on the lights.

Press [LIGHT] [STOP] to shut off the lights.

Adjusting the brightness:

Press [LIGHT] and then either [▲] or [▼] to adjust the brightness.

Turning on the lights to a pre-set level:

Press [LIGHT] and the number of the preferred level.

See the list of pre-set levels below:

No. 1	approx. 10%
No. 2	approx. 20%
No. 3	approx. 30%
No. 4	approx. 40%
No. 5	approx. 50%
No. 6	approx. 60%
No. 7	approx. 70%
No. 8	approx. 80%
No. 9	approx. 90%
No. 10	approx. 100%

See under "Installation of light scenarios" if you wish to make your own levels.

By installing more BossDim Wall Euro you will get the opportunity to control your lights individually. You will also be given the opportunity to make light scenarios, which are adapted to eg. reading, cleaning or an optimal AV experience.

Close-up Control:

Turning on and shutting off the lights:

One short press of the left side of the bar will turn on the lights. One short press of the right side of the bar will turn off the lights.

Adjusting the lights:

One longer press of the left side of the bar will adjust the light towards maximum.

One longer press of the right side of the bar will adjust the light towards minimum.

Via Remote Control:

Turning on the lights:

Press **[LIGHT]** followed by **[LIST]** until the word <LAMP> is shown on the display. Then press the light-number you have chosen for the dimmer, followed by **[GO]**, to turn on the lights.

Shutting off the lights:

Press **[LIGHT]** followed by **[LIST]** until the word <LAMP> is shown on the display. Then press the light-number you have chosen for the dimmer, followed by **[GO]** to turn on the lights.

Adjusting the brightness:

Press **[LIGHT]** followed by **[LIST]** until the word <LAMP> is shown on the display. Then press the lamp number you have chosen, followed by either **[▲]** or **[▼]** to adjust the brightness.

Combined control of several BossDim Wall Euro

Choosing a light scenario:

Press **[LIGHT]** followed by the number of the chosen light scenario. After a couple of seconds the lights, which are in this light scenario, will turn on at a pre-set level. The pre-set level can be turned off with **[GO]**, and the lights will turn on immediately.

Turning the lights off after a light scenario:

Press **[LIGHT]** followed by **[STOP]**

Adapting the brightness after choosing a light scenario:

Press **[LIGHT]** followed by either **[▲]** or **[▼]**.

This adjustment won't change the pre-set light scenario.

How to program a light scenario is described under "Programming a light scenario"

Programming a lamp number:

1. Press both left and right side of the bar and hold them in for four seconds. When the four seconds are up, a red light diode under the bar will begin flashing. Now BossDim Wall Euro is ready for programming a lamp-number.
2. Press **[LIGHT]** followed by **[LIST]** until the word <LAMP> is shown in the display.
3. Press the chosen lamp-number (eg. 1) followed by **[GO]**. The red light diode under the bar will stop flashing and BossDim Wall Euro is now programmed with lamp-number 1.

Programming a light scenario:

1. Press both left and right side of the bar and hold them in for four seconds. When the four seconds are up, a red light diode under the bar will begin flashing. Now BossDim Wall Euro is ready to program a light scenario.
2. Press **[LIGHT]** and adapt the brightness via **[▲]** or **[▼]** until the desired brightness is reached.
3. Press the chosen light scenario number (eg. 1) followed by **[GO]**. The red light diode will now stop flashing and BossDim Wall Euro is now programmed with a brightness under light scenario 1.

Cancelling a light scenario:

1. Press both left and right side of the bar and hold them in for four seconds. When the four seconds are up, a red light diode under the bar will begin flashing. Now the BossDim Wall Euro is ready for a programming a light scenario.
2. Press the desired light scenario number (eg. 8) followed by **[RED]**. The red light diode under the bar will stop flashing and the BossDim Wall Euro is now cancelled and will not be in light scenario 8 anylonger.

